

Implantology

	Transmission:
No. 5055	4:1
No. 5058	8:1
No. 5060	16:1
No. 5063	32:1
No. 5065	70:1
No. 5068	128:1



Winkel-Handstück, **Untersetzung**, mit Sprühdüse, Gesamtlänge 100–110 mm, **grüner Ring**, für Werkzeuge mit Dentalschaft.

Hand piece, angled, **reduction**, with spray nozzle, total length 100–110 mm, **green ring**, for burrs with dental shanks.

Pieza de mano acodada, **reducción**, con tobera pulverizadora, longitud total 100–110 mm, **anillo verde**, para utensilios con vástago dental.

Pièce à main angulaire, **réduction**, longueur totale 100–110 mm, **anneau vert**, pour outils à tige dentaire.

Manipolo angolato, **riduzione**, con spruzzatore, lunghezza totale 100–110 mm, **anello verde** e per strumenti con asta dentale.

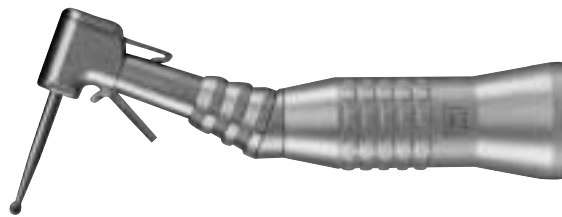

No. 5050

Winkel-Handstück, **Übersetzung 1:1**, 40'000 U/min., mit Sprühdüse, Gesamtlänge 90 mm, für Werkzeuge mit Dentalschaft.

Hand piece, angled, **transmission 1:1**, 40'000 rpm, with spray nozzle, total length 90 mm, for burrs with dental shanks.

Pieza de manco acodada, **transmisión 1:1**, 40'000 r.p.m., con tobera pulverizadora, longitud total 90 mm, para utensilios con vástago dental.

Pièce à main angulaire, **rapport transmission 1:1**, 40'000 t.p.m., longueur totale 90 mm, pour outils à tige dentaire.

Manipolo angolato, **trasmissione 1:1**, 40'000 giri/min., con spruzzatore, lunghezza totale 90 mm, per strumenti con asta dentale.

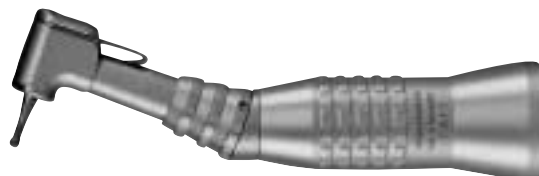

No. 1059

Winkel-Handstück, **Übersetzung 1:1**, 40'000 U/min., Gesamtlänge 90 mm, für Werkzeuge mit Dentalschaft.

Hand piece, angled, **transmission 1:1**, 40'000 rpm, total length 90 mm, for burrs with dental shanks.

Pieza de manco acodada, **transmisión 1:1**, 40'000 r.p.m., longitud total 90 mm, para utensilios con vástago dental.

Pièce à main angulaire, **rapport transmission 1:1**, 40'000 t.p.m., longueur totale 90 mm, pour outils à tige dentaire.

Manipolo angolato, **trasmissione 1:1**, 40'000 giri/min., lunghezza totale 90 mm, e per strumenti con asta dentale.



No. 1710

Handstück, **Übersetzung 1:1**, 40'000 U/min, mit Sprühdüse, Drehspannung, Gesamtlänge 90 mm, für Werkzeuge ab 44 mm Länge und 2,35 mm Schaftdurchmesser, sowie Bohrer mit Dentalschaft.

Hand piece, **transmission 1:1**, 40'000 rpm, with spray nozzle, to be tightened by turning, total length 90 mm, for burrs from 44 mm length and shanks with \varnothing 2.35 mm and for burrs with dental shanks.

Pieza de mano, **transmisión 1:1**, 40'000 r.p.m., con tobera pulverizadora, tensión de torsión, longitud total 90 mm, para utensilios de una longitud a partir de 44 mm y vástago de \varnothing 2,35 mm, además brocas con vástago dental.

Pièce à main, **rapport transmission 1:1**, 40'000 t.p.m., avec conduite de pulvérisation, à serrer en tournant, longueur totale 90 mm, pour outils à partir de 44 mm de longueur et 2,35 mm de diamètre de tige, et pour des fraises à tige dentaire.

Manipolo, **trasmissione 1:1**, 40'000 giri/min., con spruzzatore, tensione trifase, lunghezza totale 90 mm, per strumenti da 44 mm di lunghezza con asta \varnothing di 2,35 mm e per trapano con asta dentale.

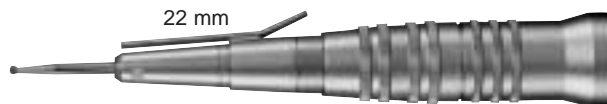

No. 1950

Handstück mittel, **Übersetzung 1:1**, 40'000 U/min, mit Sprühdüse, Drehspannung, Gesamtlänge 104 mm, für Werkzeuge ab 70–95 mm Länge und 2,35 mm Schaftdurchmesser, sowie Bohrer mit Dentalschaft.

Hand piece midle, **transmission 1:1**, 40'000 rpm, with spray nozzle, to be tightened by turning, total length 104 mm, for burrs from 70–95 mm length and shanks with \varnothing 2.35 mm and for burrs with dental shanks.

Pieza de mano, medio, **transmisión 1:1**, 40'000 r.p.m., con tobera pulverizadora, tensión de torsión, longitud total 104 mm, para utensilios de una longitud a partir de 70–95 mm y vástago de \varnothing 2,35 mm, además brocas con vástago dental.

Pièce à main midi, **rapport transmission 1:1**, 40'000 t.p.m., avec conduite de pulvérisation, à serrer en tournant, longueur totale 104 mm, pour outils à partir de 70–95 mm de longueur et 2,35 mm de diamètre de tige, et pour des fraises à tige dentaire.

Manipolo, mezzo, **trasmissione 1:1**, 40'000 giri/min., con spruzzatore, tensione trifase, lunghezza totale 104 mm, per strumenti da 70–95 mm di lunghezza con asta \varnothing di 2,35 mm e per trapano con asta dentale.

No. 1951

GL = 127 mm



45 mm

No. 1952

GL = 157 mm



75 mm

No. 1951/1952

Handstück lang, **Übersetzung 1:1**, 40'000 U/min, mit Sprühdüse, Drehspannung, für Werkzeuge ab 90–125 mm Länge und 2,35 mm Schaftdurchmesser, sowie Bohrer mit Dentalschaft.

Hand piece long, **transmission 1:1**, 40'000 rpm, with spray nozzle, to be tightened by turning, for burrs from 90–125 mm length and shanks with \varnothing 2.35 mm and for burrs with dental shanks.

Pieza de mano, longo, **transmisión 1:1**, 40'000 r.p.m., con tobera pulverizadora, tensión torsión, para utensilios de una longitud a partir de 90–125 mm y vástago de \varnothing 2,35 mm, además brocas con vástago dental.

Pièce à main, long, **rapport transmission 1:1**, 40'000 t.p.m., avec conduite de pulvérisation, à serrer en tournant, pour outils à partir de 90–125 mm de longueur et 2,35 mm de diamètre de tige, et pour des fraises à tige dentaire.

Manipolo, lungo, **trasmissione 1:1**, 40'000 giri/min., con spruzzatore, tensione trifase, per strumenti da 90–125 mm di lunghezza con asta \varnothing di 2,35 mm e per trapano con asta dentale.

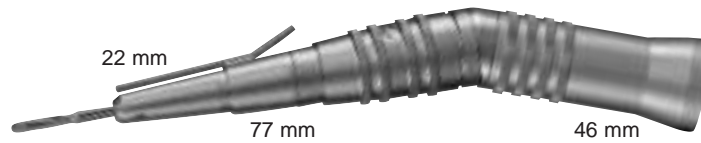

No.1960

Winkel-Handstück, **Übersetzung 1:1**, 40'000 U/min, mit Sprühdüse, Drehspannung, Gesamtlänge 130 mm, für Werkzeuge von 70–95 mm Länge und 2,35 mm Schaftdurchmesser.

Hand piece, angled, **transmission 1:1**, 40'000 rpm, with spray nozzle, to be tightened by turning, total length 130 mm, for burrs ranging from 70–95 mm in length and shank Ø 2.35 mm.

Pieza de mano acodada, **transmisión 1:1**, 40'000 r.p.m., con tobera pulverizadora, tensión de torsión, longitud total 130 mm, para utensilios de una longitud de 70–95 mm y vástago de Ø 2,35 mm.

Pièce à main angulaire, **rapport transmission 1:1**, 40'000 t.p.m., avec conduite de pulvérisation, à serrer en tournant, longueur totale 130 mm, pour outils d'une longueur de 70–95 mm et d'un diamètre de tige de 2,35 mm.

Manipolo angolato, **trasmissione 1:1**, 40'000 giri/min., con spruzzatore, tensione trifase, lunghezza totale 130 mm, e per strumenti da 70–95 mm di lunghezza e 2,35 mm Ø dell'asta.

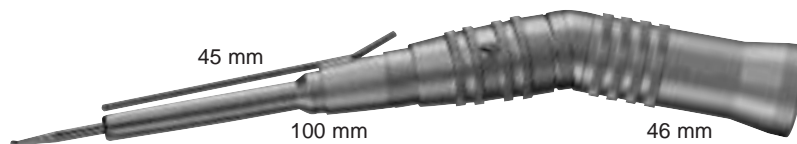

No. 1961

Winkel-Handstück, **Übersetzung 1:1**, 40'000 U/min, mit Sprühdüse, Drehspannung, Gesamtlänge 130 mm, für Werkzeuge von 90–125 mm Länge und 2,35 mm Schaftdurchmesser.

Hand piece, angled, **transmission 1:1**, 40'000 rpm, with spray nozzle, to be tightened by turning, total length 130 mm, for burrs ranging from 90–125 mm in length and shank Ø 2.35 mm.

Pieza de mano acodada, **transmisión 1:1**, 40'000 r.p.m., con tobera pulverizadora, tensión de torsión, longitud total 130 mm, para utensilios de una longitud de 90–125 mm y vástago de Ø 2,35 mm.

Pièce à main angulaire, **rapport transmission 1:1**, 40'000 t.p.m., avec conduite de pulvérisation, à serrer en tournant, longueur totale 130 mm, pour outils d'une longueur de 90–125 mm et d'un diamètre de tige de 2,35 mm.

Manipolo angolato, **trasmissione 1:1**, 40'000 giri/min., con spruzzatore, tensione trifase, lunghezza totale 130 mm, e per strumenti da 90–125 mm di lunghezza e 2,35 mm Ø dell'asta.

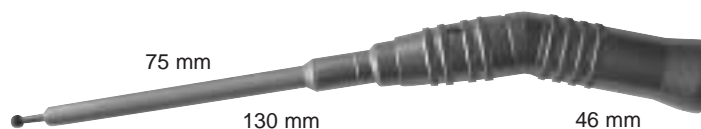

No. 1962

Winkel-Handstück, **Übersetzung 1:1**, 40'000 U/min, mit Sprühdüse, Drehspannung, Gesamtlänge 130 mm, für Werkzeuge von 125 mm Länge und 2,35 mm Schaftdurchmesser.

Hand piece, angled, **transmission 1:1**, 40'000 rpm, with spray nozzle, to be tightened by turning, total length 130 mm, for burrs ranging from 125 mm in length and shank Ø 2.35 mm.

Pieza de mano acodada, **transmisión 1:1**, 40'000 r.p.m., con tobera pulverizadora, tensión de torsión, longitud total 130 mm, para utensilios de una longitud de 125 mm y vástago de Ø 2,35 mm.

Pièce à main angulaire, **rapport transmission 1:1**, 40'000 t.p.m., avec conduite de pulvérisation, à serrer en tournant, longueur totale 130 mm, pour outils d'une longueur de 125 mm et d'un diamètre de tige de 2,35 mm.

Manipolo angolato, **trasmissione 1:1**, 40'000 giri/min., con spruzzatore, tensione trifase, lunghezza totale 130 mm, e per strumenti da 125 mm di lunghezza e 2,35 mm Ø dell'asta.

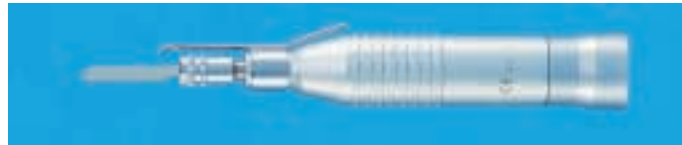

No. 5040

Mikro-Stichsäge, ohne Sägeblätter, mit INTRA-Kupplung nach ISO 3964, abnehmbares Spülrohr, mit Gabelschlüssel, empfohlene maximale Motordrehzahl: 20'000 U/min.

Micro Compass Saw, without saw blades, with INTRA coupling acc. to ISO 3964, detachable irrigation tube, with fork wrench, recommended maximum speed: 20'000 rpm.

Micro sierra, sin hojas de sierra, con acoplamiento INTRA según ISO 3964, tubo de irrigación desmontable, con llave, revolución máx. recomendada: 20'000 r.p.m.

Scie micro à guichet, sans lames de scie, avec INTRA-accouplement selon ISO 3964, tube de liquide démontable, avec clef fourchue, nombre de tours max. recommandé: 20'000 t.p.m.

Micro sega, senza lame, con INTRA-aggiunto secondo ISO 3964 tubo di lavaggio smontabile, con chiave per dado, considerato regime max. di rotazione del motore: 20'000 giri/min.

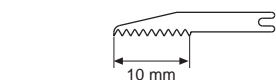

No. 5041

Sägeblätter

Saw blades

Hojas de sierra

Lame de scie

Lame da sega



No. 5042

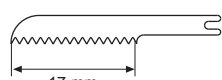

No. 5043

Verpackungseinheit 6 Stück

Packaging unit 6 pieces

En paquete de 6 piezas

Unité d'emballage 6 pièces

Confezione da 6 pezzi

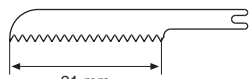

No. 5044

Blattstärke → 0,4 mm

Thickness of blade → 0.4 mm

Grosor de la hoja → 0,4 mm

Epaisseur de la lame → 0,4 mm

Spessore della lama → 0,4 mm

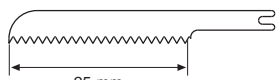

No. 5045



No. 5046

Hartmetall Raspelaufsatz

TC rasp for micro compass saw

Escofina de tungsteno para micro sierra

Râpe en tungstène pour scie micro à guichet

Raspa al tungsteno per micro sega



No. 5047

Ersatz-Sprührohr

Spare irrigation tube for micro compass saw

Tubo de recambio para irrigación para micro sierra

Canule de lavage de rechange pour scie micro à guichet

Cannula per lavaggio di ricambio per micro sega



No. 5048

Ersatz-Überwurfmutter für Spannfutter

Spare fixation nut for chuck

Tuerca de repuesto para mandril de sujeción

Ecrou fileté pour mandrin de serrage

Dado a cappello di ricambio per mandrino



No. 5092

Gabelschlüssel allein

Fork wrench only

Llave horquilla suelta

Clef seule

Chiave a forcina sola

OMS 5000

Instruments with E-Type coupling for surgical work in ENT-, ORAL- MAXILLO-FACIAL-, PLASTIC- RECONSTRUCTIVE- HAND- and NEURO-SURGERY also for IMPLANTOLOGY

**Oszillierende Mikro-Säge
Micro Oscillating Saw
Micro sierra oscilante
Scie micro oscillante
Micro sega oscillante**

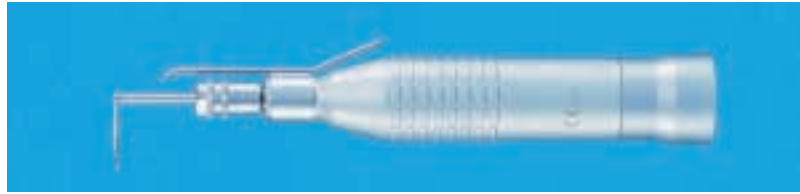

No. 5090

Oszillierende Mikro-Säge ohne Sägeblätter, mit INTRA-Kupplung nach ISO 3964, Spülrohr, mit Gabelschlüssel, empfohlene maximale Motordrehzahl: 15'000 U/min $\hat{=}$ 15'000 Oszillationen/Minute.

Micro oscillating saw without saw blades, with INTRA coupling acc. to ISO 3964, irrigation tube, with fork wrench, recommended maximum speed: 15'000 rpm $\hat{=}$ 15'000 oscillations/minute.

Micro sierra oscilante sin hojas, con acoplamiento INTRA según ISO 3964, con tubo de succión, con llave horquilla, número de revoluciones del motor recomendado: 15'000 r.p.m. $\hat{=}$ 15'000 oscilaciones por minuto.

Scie micro oscillante, sans lames de scie, avec accouplement INTRA selon ISO 3964, canule de lavage, avec clef, nombre de tours maximum recommandé: 15'000 t.p.m. $\hat{=}$ 15'000 oscillations par minute.

Micro sega oscillante senza lame, con INTRA innesto secondo ISO 3964, tubo di lavaggio, con chiave a forcina raccomandiamo massimo numeri di giri: 15'000 al minuto $\hat{=}$ 15'000 oscillazioni/min.

Die geringe Blattdicke der Sägeblätter ermöglicht sehr feine Schnitte, Blattstärke 0,4 mm

As the blades are extremely thin very delicate cuts can be achieved, thickness of blade 0.4 mm

El grosor mínimo de las hojas hace posible cortes muy finos, grosor de la hoja 0,4 mm

Les lames de scie sont très minces ce qui permet des coupes très fines, épaisseur de la lame 0,4 mm

Il sottile spessore delle lame da sega rende possibile tagli molto delicati, spessore della lama 0,4 mm

Sägeblätter mit **kurzem** Schaft, Nutzlänge: 14 mm

Saw blades with **short** shank, working length: 14 mm

Hojas de sierra con vástago **corto**, largo útil: 14 mm

Lame de scie avec tige **courte**, longueur utile: 14 mm

Lame da sega con asta **corta**, lungh. utile: 14 mm

Sägeblätter mit **langem** Schaft, Nutzlänge: 28 mm

Saw blades with **long** shank, working length: 28 mm

Hojas de sierra con vástago **largo**, largo útil: 28 mm

Lame de scie avec tige **longue**, longueur utile: 28 mm

Lame da sega con asta **lunga**, lungh. utile: 28 mm

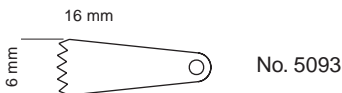

No. 5093

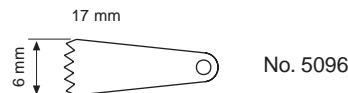

No. 5096

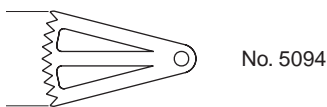

No. 5094

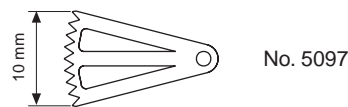

No. 5097

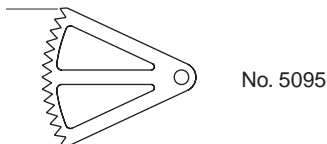

No. 5095

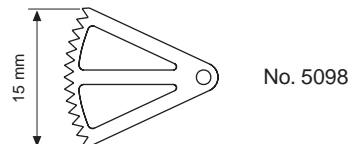

No. 5098

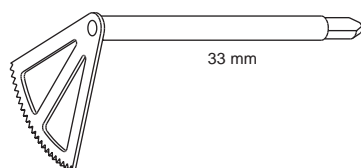

33 mm

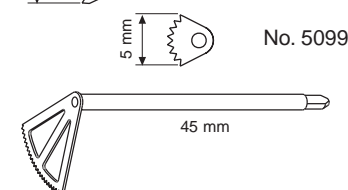

No. 5099

Verpackungseinheit 1 Stück
Packaging unit 1 piece
En paquete de 1 pieza
Unité d'emballage 1 pièce
Confezione da 1 pezzo

No. 5048

Ersatz-Überwurfmutter für Spannfutter
Spare fixation nut for chuck



Tuerca de repuesto para mandril de sujeción

Ecrou fileté pour mandrin de serrage

Dado a cappello di ricambio per mandrino

No. 5092

Gabelschlüssel allein
Fork wrench only

Llave horquilla suelta

Clef seule

Chiave a forcina sola



No. 5047

Sprühdüse

Spray nozzle

Tobera pulverizadora

Conduite de pulvérisation

Spruzzatore



MOS 5000

Instruments with E-Type coupling for surgical work in ENT-, ORAL- MAXILLO-FACIAL-, PLASTIC- RECONSTRUCTIVE- HAND- and NEURO-SURGERY also for IMPLANTOLOGY

**Mikro Säge Osseoskalpell SAGITTAL
Micro Osseoscalpel Saw SAGITTAL
Microsierra Osseoscalpel SAGITTAL
Scie micro Osseoscalpel SAGITTALE
Scalpello Osseo, micro sega SAGGITALE**



No. 5110

Osseoskalpell, Mikro-Säge mit sagittalem Schnitt, Pendelhub, besonders geeignet für zweidimensionale Schnittführungen; ohne Sägeblätter, mit INTRA-Kupplung nach ISO 3964, Spülrohr, mit Gabelschlüssel, empfohlene maximale Motordrehzahl: 20'000 U/min.

Osseoscalpel, micro saw with sagittal cut, oscillating hub, especially suitable for two-dimensional cutting; without saw blade, with INTRA coupling acc. to ISO 3964, with fork wrench, recommended maximum speed: 20'000 rpm.

Microsierra Osseoscalpel con corte sagital, elevación de péndulo, especialmente apropiada para cortes bidimensionales; sín hojas, con INTRA-acoplamiento según ISO 3964, tubo de irrigación con llave, revolución max. de motor recomendada: 20'000 r.p.m.

Osséoscalpel, scie micro à coupe sagittale, par voie excentrique, particulièrement conçu pour des coupes à deux dimensions; sans lames de scie, avec INTRA-accouplement selon ISO 3964, conduite de lavage avec clef fourchue, nombre de tours max. recommandé: 20'000 t.p.m.

Scalpello Osseo, micro sega con taglio saggitale, corsa del pendolo, adatto specialmente per guida taglio bidimensionale; senza lame, con INTRA-aggiunto secondo ISO 3964, tubo di lavaggio con chiave per dado, considerato regime max. di rotazione del motore: 20'000 giri/min.

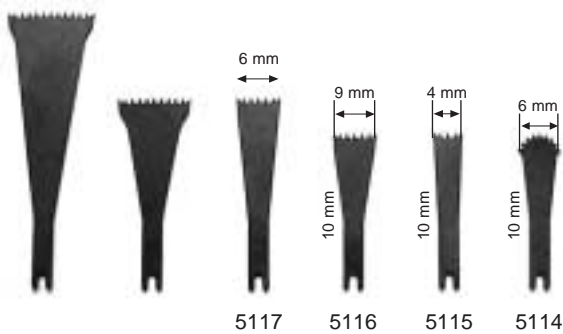

Sägeblätter
Saw blades
Hojas de sierra
Lame de scie
Lame da sega

Blattstärke → 0,4 mm
Thickness of blade → 0.4 mm
Grosor de la hoja → 0,4 mm
Epaisseur de la lame → 0,4 mm
Spessore della lama → 0,4 mm

Verpackungseinheit 6 Stück
Packaging unit 6 pieces
En paquete de 6 piezas
Unité d'emballage 6 pièces
Confezione da 6 pezzi

No. 5048

Ersatz-Überwurfmutter für Spannfutter
Spare fixation nut for chuck



Tuerca de racor de repuesto para mandril de sujeción
Ecrou fileté pour mandrin de serrage
Dado a cappello di ricambio per mandrino

No. 5092

Gabelschlüssel allein
Fork wrench only

Llave horquilla suelta
Clef seule
Chiave a forcina sola



No. 5047

Sprühdüse
Spray nozzle

Tobera pulverizadora
Conduite de pulvérisation
Spruzzatore



Das universell einsetzbare Mikroosteotom mit Pendelhubmechanik eignet sich hervorragend für den Einsatz in den Bereichen der maxillo- und craniofacialen Chirurgie.

The universally applicable micro osteotome with oscillating hub mechanics is excellently suitable for application in maxillo and craniofacial surgery.

El microosteotomo con la técnica de elevación de péndulo, se puede utilizar universalmente, es apropiado muy bien para la gama de la Cirugía Maxilo y Craniofacial.

L'ostéotome micro à fonctionnement excentrique est universellement applicable et est particulièrement qualifié pour l'utilisation dans les domaines de la chirurgie cranio-maxillofaciale.

Il microosteotomo usabile universalmente con la meccanica corsa del pendolo si adatta benissimo per l'impiego dei settori chirurgia, maxillo e cranio-facciale.

CAW 3000

Winkel-Handstück für Chirurgiedrähte Ø 0,5–1,6 mm
Hand pieces angled for surgery wires Ø 0.5–1.6 mm
Piezas de mano acodada para alambres quirúrgicos Ø 0,5–1,6 mm
Pièces à main angulaire pour fils de chirurgie Ø 0,5–1,6 mm
Manipoli angolate per fili di chirurgia Ø 0,5–1,6 mm

for **ORAL and MAXILLOFACIAL SURGERY, PLASTIC and RECONSTRUCTIVE SURGERY, NEURO-SURGERY, HAND SURGERY**

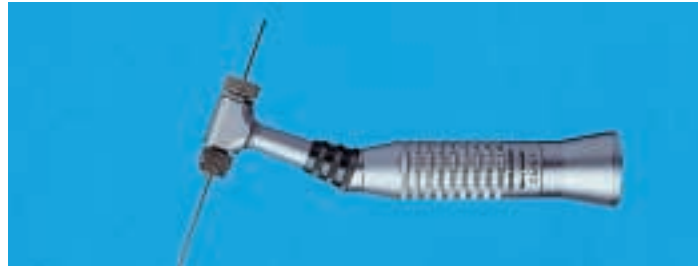

No. 5010

Winkel-Handstück, **Untersetzung 16:1**, 2'500 U/min, Gesamtlänge 90 mm, **grüner Ring**, für Chirurgiedrähte Ø 0,5–1,6 mm

Hand piece, angled, **reduction 16:1**, 2'500 rpm, total length 90 mm, **green ring**, for surgery wires Ø 0.5–1.6 mm

Pieza de mano acodada, **reducción 16:1**, 2'500 r.p.m. longitud total 90 mm, **anillo verde**, para alambres quirúrgicos Ø 0,5–1,6 mm

Pièce à main angulaire, **réduction 16:1**, 2'500 t.p.m. longueur totale 90 mm, **anneau vert**, pour fils de chirurgie Ø 0,5–1,6 mm

Manipolo angolato, **riduttore 16:1**, 2'500 giri/min., lunghezza totale 90 mm, **anello verde** e per fili di chirurgia Ø 0,5–1,6 mm



No. 4990–5018

Verpackungseinheit 10 Stück

Packaging unit 10 pieces

En paquete de 10 piezas

Unité d'emballage 10 pièces

Confezione da 10 pezzi

	diam. mm Ø mm	length mm Länge mm longueur mm	
No. 4990	0,5	70	} 5019 chucks Spannzange pinces pinzas
No. 4992	0,6	70	
No. 5013	0,8	70	
No. 5014	1,0	70	} 5012 chucks Spannzange pinces pinzas
No. 5015	0,8	150	
No. 5016	1,0	150	
No. 5017	1,2	150	
No. 5018	1,5	150	



mit INTRA-Kupplung nach DIN 13940/ISO-DIS 3964

with INTRA coupling acc. to DIN 13940/ISO-DIS 3964

con acoplamiento INTRA según DIN 13940/ISO-DIS 3964

avec accouplement INTRA selon DIN 13940/ISO-DIS 3964

con INTRA-aggiunto secondo DIN 13940/ISO-DIS 3964

Surgical Motor System Chirurgie-Motor-System



For maximum micro-surgery versatility under sterile condition in order to avoid infections and tissue damage due to the generation of heat.

Für praxisgerechtes chirurgisches Arbeiten unter sterilen Bedingungen, zur Vermeidung von Infektionen und Gewebe-Beschädigungen durch Wärmeentwicklung.

No. 2010

MD 10 Surgical Motor-System

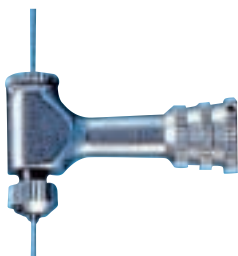

No. 5011

Winkelstückkopf
Contra-angle Head
Pieza acodada
Contre-angle tête
Testina contrangolo



No. 5092

Gabelschlüssel allein
Fork wrench only
Llave horquilla suelta
Clef seule
Chiave a forcina sola



No. 1993



No. 1992



No. 1991



No. 1990

- No. 1993** Dermatom 12 mm E-Fitting
- No. 1992** Dermatom 25 mm E-Fitting
- No. 1991** Dermatom 50 mm E-Fitting
- No. 1990** Dermatom 75 mm E-Fitting



Dermatom mit INTRA-Kupplung nach ISO 3964, empfohlene maximale Motordrehzahl: 8'000 U/min.
Dermatome with INTRA coupling acc. to ISO 3964, recommended maximum speed: 8'000 rpm.
Dermatomo con acoplamiento INTRA según ISO 3964, revolución máxima recomendada: 8'000 r.p.m.
Dermatome avec INTRA-accouplement selon ISO 3964, nombre de tours max. recommandé: 8'000 t.p.m.
Dermatomo con INTRA-aggiunto secondo ISO 3964, considerato regime max. di rotazione del motore: 8'000 giri/min.

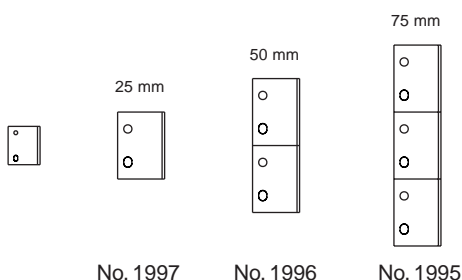

No. 1997

No. 1996

No. 1995

- No. 1995** 75 mm
- No. 1996** 50 mm
- No. 1997** 25 mm
- No. 1998** 12 mm

Ersatzklingen für Dermatom unsteril, Packung/10 Stück
Spare Blades for Dermatom non-sterile, package/10 pieces
Hojas de repuesto para dermatomo no estéril, paquete/10 piezas
Lames de rechange pour dermatome, non stériles, boîte/10 pièces
Lame di ricambio per dermatomo non sterili, pacco/10 pezzi

Die Stärke des Spalthaut-Transplantats ist mittels Rändelschraube von 0,05–0,55 mm einstellbar
The thickness of the mucosal graft can be adjusted from 0.05 to 0.55 mm by means of the knurled screw
El espesor del injerto de mucosa, se ajusta de 0,05 hasta 0,55 mm mediante tornillo
L'épaisseur du greffon muqueux est ajustée par la vis mottée et peut varier entre 0,05 et 0,55 mm
Mediante la vite regolatrice, lo spessore dei prelievi del trapianto di mucosa può essere variato da mm. 0,05 fino a mm. 0,55.



No. 1970

No. 1970



Mucotom
Mucotome
Mucotomo
Mucotome
Mucotomo

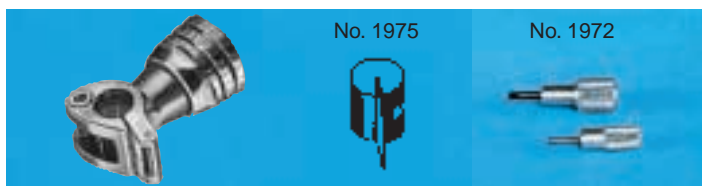

No. 1975

No. 1972

- No. 1971**
Mucotom-Kopf
Mucotome Head
Mucotomo Cabezas
Mucotome-tête
Mucotomo-Testina

- No. 1975**
Ersatzklingen für Mucotom unsteril, Packung/5 Stück
Spare Blades for Mucotom non-sterile, package/5 pieces
Hojas de repuesto para mucotomo no estéril, paquete/5 piezas
Lames de rechange pour mucotome, non stériles, boîte/5 pièces
Lame di ricambio per mucotomo, non sterili, pacco/5 pezzi

Mucotom mit INTRA-Kupplung nach ISO 3964, empfohlene maximale Motordrehzahl: 8'000 U/min., Schnittstärke: 0,5 mm, Schnittbreite: 6/8/10 mm

Mucotome with INTRA coupling acc. to ISO 3964, recommended maximum speed: 8'000 rpm., thickness of graft: 0.5 mm, cutting width: 6/8/10 mm

Mucotomo con acoplamiento INTRA según ISO 3964, revolución máxima recomendada: 8'000 r.p.m. de corte espesor: 0,5 mm, anchura de corte 6/8/10 mm

Mucotome avec INTRA-accouplement selon ISO 3964, nombre de tours max. recommandé: 8'000 t.p.m. épaisseur d'incision 0,5 mm, largeur d'incision 6/8/10 mm

Mucotomo con INTRA-aggiunto secondo ISO 3964, considerato regime max. di rotazione del motore: 8'000 giri/min. spessore di taglio 0,5 mm, Larghezza di taglio 6/8/10 mm

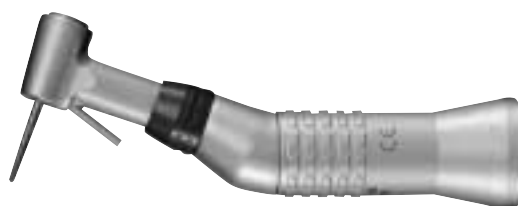

No. 5081

Winkel-Handstück, **Übersetzung 1:5**, 200'000 U/min, mit Sprühdüse, Druckknopfspannung, Gesamtlänge 90 mm, **roter Ring**, für Werkzeuge mit Dentschaft, Ø 1,6 mm.

Hand piece, angled, **transmission 1:5**, 200'000 rpm, with spray nozzle, push-button system, total length 90 mm, **red ring**, for burrs with dental shanks, Ø 1.6 mm.

Pieza de mano acodada, **transmisión 1:5**, 200'000 r.p.m. con tobera pulverizadora, tensión de presión de botón, longitud total 90 mm, **anillo rojo** para utensilios con vástago dental, Ø 1,6 mm.

Pièce à main angulaire, **rapport transmission 1:5**, 200'000 t.p.m., serrage «bouton-pression», longueur totale 90 mm, **anneau rouge**, pour outils à tige dentaire, Ø 1,6 mm.

Manipolo angolato, **trasmissione 1:5**, 200'000 giri/min., con spruzzatore, tensione a pulsante, lunghezza totale 90 mm, **anello rosso** e per strumenti con asta dentale, Ø 1,6 mm.

Art. No.

5051	1:1
5056	4:1
5057	8:1 Endo with mini head
5059	8:1
5061	16:1
5064	32:1 Endo with mini head
5066	70:1
5069	128:1 Endo with mini head

Endodontology



No. 5057

Winkel-Handstück, **Untersetzung**, 40'000 U/min, Druckknopfspannung, Gesamtlänge 90 mm, **grüner Ring**, für Werkzeuge mit Dentschaft, Ø 2,35 mm.

Hand piece, angled, **reduction**, 40'000 rpm, push-button system, total length 90 mm, **green ring**, for burrs with dental shanks, Ø 2.35 mm.

Pieza de mano acodada, **reducción**, 40'000 r.p.m. tensión de presión de botón, longitud total 90 mm, **anillo verde**, para utensilios con vástago dental, Ø 2,35 mm.

Pièce à main angulaire, **réduction**, 40'000 t.p.m., serrage «bouton-pression», longueur totale 90 mm, **anneau vert**, pour outils à tige dentaire, Ø 2,35 mm.

Manipolo angolato, **riduzione**, 40'000 giri/min., tensione a pulsante, lunghezza totale 90 mm, **anello verde** e per strumenti con asta dentale, Ø 2,35 mm.

Interdental-Handpiece



No. 1713

Winkel-Handstück, **Untersetzung 4:1**, 10'000 U/min, mit Sprühdüse, Gesamtlänge 90 mm, **grüner Ring**, Rootshape®-Feile.

Hand piece, angled, **reduction 4:1**, 10'000 rpm, with spray nozzle, total length 90 mm, **green ring**, Rootshape® files.

Pieza de mano acodada, **reducción 4:1**, 10'000 r.p.m., con tobera pulverizadora, longitud total 90 mm, **anillo verde**, Lime Rootshape®.

Pièce à main angulaire, **réduction 4:1**, 10'000 t.p.m., longueur totale 90 mm, **anneau vert**, Limes Rootshape®.

Manipolo angolato, **riduzione 4:1**, 10'000 giri/min. con spruzzatore, lunghezza totale 90 mm, **anello verde**, Lime Rootshape®.

Rootshape®-Feile
 Rootshape® files
 Lime Rootshape®
 Limes Rootshape®

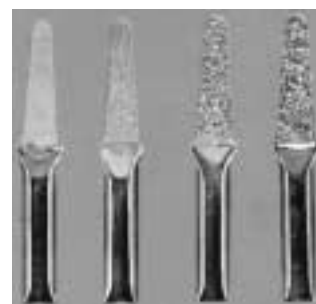

Proxo 3 **17133**
 Proxo 2 **17132**
 Proxo 1 **17131**
 Proxo 0 **17130**
 Set Art. **17134**



No. 1706

Schlauchset, Einweg

Spare tube, disposable

Manguera de repuesto, no retornable, para pieza de mano

Tuyau flexible de rechange, usage unique le raccord de la poignée

Tube flessibile di ricambio, mono uso, al portastrumenti



No. 1708

Schlauchset, Einweg, zum Anschluss an 3-Weg-Hahn

Spare tube, disposable for 3-Way connection

Manguera de repuesto, no retornable, para acoplamiento de grifo de tres vías

Tuyau flexible de rechange, usage unique pour le raccord de la 3-voies-robinets

Tube flessibile di ricambio, mono uso, per collegamento al rubinetto a tre vie

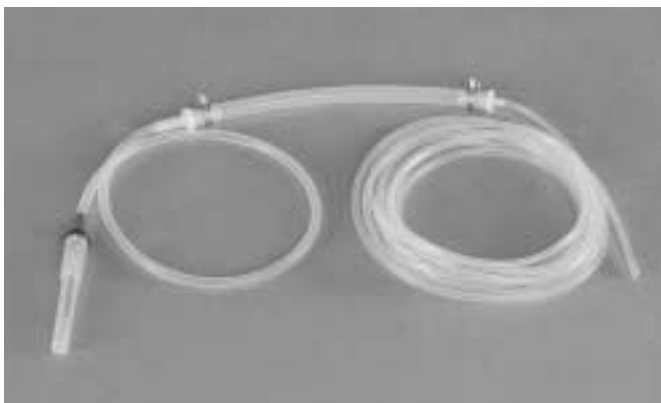

No. 1704

Ersatzschlauch, sterilisierbar

Spare tube, sterilizable

Manguera de repuesto, esterilizable

Tuyau flexible de rechange, stérilisable

Tube flessibile di ricambio, sterilizzabile



No. 1744

Ersatzschlauch, sterilisierbar zum Anschluss an 3-Weg-Hahn

Spare tube, sterilizable for 3-Way connection

Manguera de repuesto, esterilizable para acoplamiento de grifo de tres vías

Tuyau flexible de rechange, stérilisable pour le raccord de la robinet à trois voies

Tube flessibile di ricambio, sterilizzabile per collegamento al rubinetto a tres vie

Handstücke
Hand pieces
Piezas de mano
Pièces à main
Manipoli



Craniotom
Craniotome
Craniotom
Craniotome
Craniotomo

Ersatzfräser
 Spare cutters
 Fraise de rechange
 Fresas de repuesto



No. 1973

No. 3102

Handstück, **Übersetzung 1:1**, 40'000 U/min, mit Sprühdüse, Drehspannung, Gesamtlänge 110 mm, für Werkzeuge ab 44 mm Länge und 2,35 mm Schaftdurchmesser, sowie Bohrer mit Dentschaft.

Hand piece, **transmission 1:1**, 40'000 rpm, with spray nozzle, to be tightened by turning, total length 110 mm, for burrs from 44 mm length and shanks with Ø 2.35 mm and for burrs with dental shanks.

Pieza de mano, **transmisión 1:1**, 40'000 r.p.m. con tobera pulverizadora, tensión de torsión, longitud total 110 mm, para utensilios de una longitud a partir de 44 mm y vástago de Ø 2,35 mm, además brocas con vástago dental.

Pièce à main, **rapport transmission 1:1**, 40'000 t.p.m., avec conduite de pulvérisation, à serrer en tournant, longueur totale 110 mm, pour outils à partir de 44 mm de longueur et 2,35 mm de diamètre de tige, et pour des fraises à tige dentaire.

Manipolo, **trasmisione 1:1**, 40'000 giri/min., con spruzzatore, tensione trifase, lunghezza totale 110 mm, per strumenti da 44 mm di lunghezza con asta Ø di 2,35 mm e per trapano con asta dentale.

No. 1955

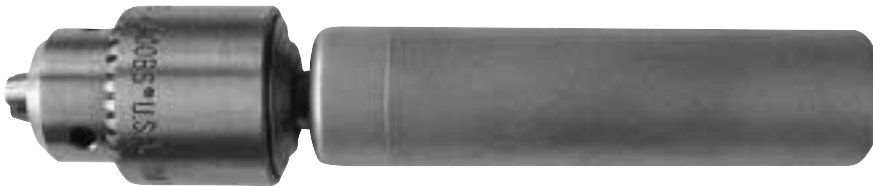

INTRA-Kupplung
 INTRA Coupling
 INTRA-acoplamiento
 INTRA-accouplement
 INTRA-Aggiunto

No. 1965

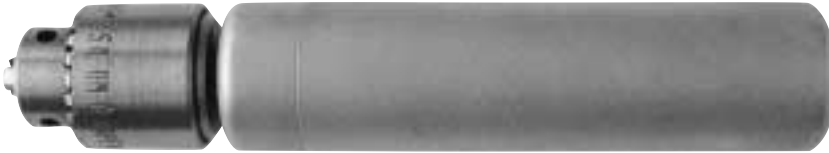

Handstück, **Untersetzung 4:1**, 4'000 U/min, Gesamtlänge 121 mm, für Werkzeuge mit Schaftdurchmesser 0–6,5 mm.

Hand piece, **reduction 4:1**, 4'000 rpm, total length 121 mm, for burrs with shanks, Ø 0–6.5 mm.

Pieza de mano, **reducción 4:1**, 4'000 r.p.m., longitud total 121 mm, para utensilios con vástago de Ø 0–6,5 mm.

Pièce à main, **réduction 4:1**, 4'000 t.p.m., longueur totale 121 mm, pour outils à partir des fraises à tige Ø 0–6,5 mm.

Manipolo, **riduzione 4:1**, 4'000 giri/min., lunghezza totale 121 mm, e per strumenti e per trapano con Ø 0–6,5 mm.



1963
 Sprühdüse
 Spray nozzle
 Tobera pulverizadora
 Conduite de pulvérisation
 Spruzzatore



No. 982166
 Chuck 0–4 mm

Schlüssel Nr. 982176
 Key No. 982176
 Llave no. 982176
 Clé no 982176
 Chiave no. 982176



No. 982167
 Chuck 0–6,5 mm

Schlüssel Nr. 982177
 Key No. 982177
 Llave no. 982177
 Clé no 982177
 Chiave no. 982177

Universal-Dreibackenfutter mit Spannschlüssel für Schaftstärken bis Ø 0–6,5 mm

Three jaw chuck, with key for shanks up to Ø 0–6.5 mm

Patabrocas de corona dentada con llave para utensilios con vástago de Ø 0–6,5 mm

Mandrin avec clé pour outils à partir des fraises à tige Ø 0–6,5 mm

Mandrino a cremagliera con chiave e per strumenti e per trapano con Ø 0–6,5 mm

Schädeltrepane:

- Automatische Auskupplung
- Spezialschliff
- Schlüssellos zerlegbar
- Reinigungsfreundlich
- Dampfsterilisierbar bis 3 bar = 143°C

Trépanos crâniens:

- Désaccouplement automatique
- Forme spéciale
- Démontable sans clef
- Facile à nettoyer
- Stérilisable à la vapeur jusqu'à 3 bar = 143°C



Cranial perforators:

- Automatic perforators
- Special sharpening
- No key is needed for dismantling
- Easy to clean
- Can be sterilized in a steam sterilizer up to 3 bar overpressure = 143°C

Trépanos craneales:

- Desacoplamiento automático
- Afilado especial
- Desmontables sin precisar de llave
- De fácil limpieza
- Esterilizables a vapor hasta 3 bares = 143°C



	Handstücke Hand pieces Piezas de mano Pièces à main Manipoli	Durchmesser Fräser Diameter Cutter Diámetro-Fresa Diamètre de fraises Diametro di fresa			
Schädeltrepane Cranial trepans Trépanos craneales Trépan crânién Perforatori teca cranica		1955	2805	2806	2807
Ersatzfräser Spare cutters Fraise de rechange Fresas de repuesto Frese di ricambio			2825	2826	2827

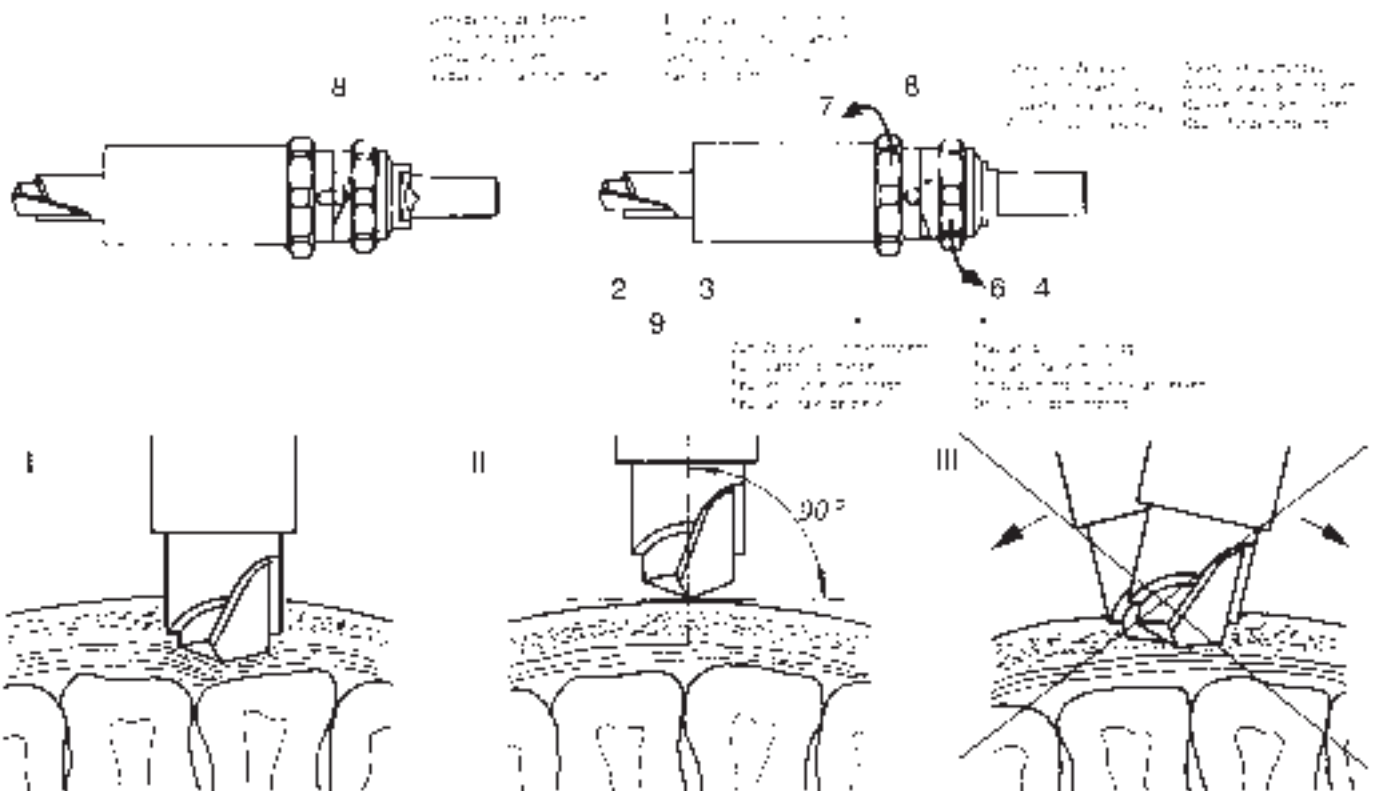

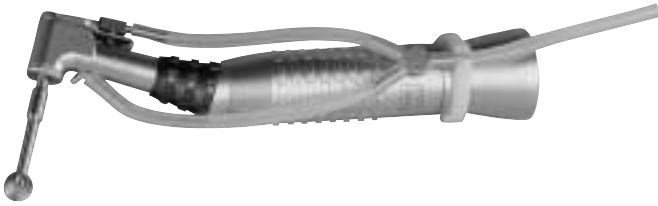

Winkel-Handstück mit Y-Verbinder
 Hand pieces angled with Y-connector
 Piezas de mano acodada con conector-Y
 Pièces à main angulaire avec Y-connecteur
 Manipoli angolate con Y-connettore



No. 1712
 INTRA-Kühlrohr Type 2
 INTRA-Cooling tube Typ 2
 INTRA-Irrigation tubo Tipo 2
 INTRA-Irrigation tube Type 2
 INTRA-Irrigazione tubo Tipo 2



No. 1777
 Y-Verbinder
 Y-Connector
 Y-Conector
 Y-Connecteur
 Y-Connettore

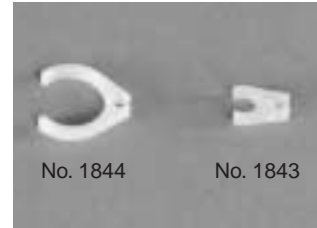

No. 1844
 Clip CS
No. 1843
 Clip CL



No. 4105

No. 1805

No. 1805
 Handstück für externe Kühlung und zum Auswaschen von Wunden, mit austauschbarer Kanüle No. 4105

Hand piece for external cooling and for washing wounds, with interchangeable needle No. 4105

Pieza de mano para irrigación externa y lavado de heridas, con cánula sustituible No. 4105

Pièce à main pour refroidissement externe et pour laver les blessures, avec réchangeable canule No. 4105

Manipolo per irrigazione esterna per sciacquare le ferite, con cannula ricambiabile No 4105

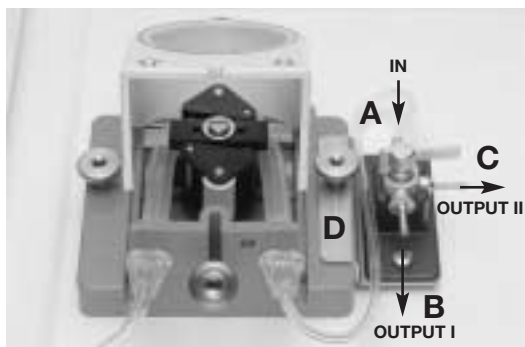

No. 1776
 3-way-water-value
 3-Weg-Hahn
 3-voies-robinets

Lever-Position:
 Hebel-Positionen:
 Levier-Positions: A-B-C-D

A = Output I & II
 B = Output I - On
 C = No Outlet
 D = Output II - On

Pumpen-Schläuche auswechselbar

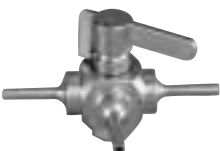
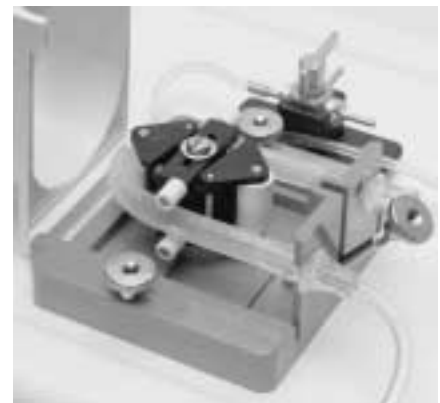

No. 50431
 3-Weg-Hahn
 3-Way Valve
 3-Vias Valvolas
 3-Voies Robinets
 3-Vie Rubinetto



No. 1776
 3-Weg-Hahn mit Halter
 3-Way Valve with support
 3-Vias grifo con soporte
 3-Voies Robinets avec appui
 3-Vie Rubinetto con supporto

TORQUE ANGLE DRIVER

**Winkelschraubinstrument
Angular Screwing Instrument
Destornillador de angulo
Tournevis angulaire
Strumento per viti ad angolo**



No. 17140-17159

Einsätze für Winkelschraubinstrument
Inserts for angular screwing instrument
Injertos para destornillador de angulo
Embouts pour le tournevis angulaire
Pezzi inseribili per strumento

Reduction 16:1

Winkelschraubinstrument, wahlweise für Handantrieb oder Mikromotor mit INTRA-Kupplung nach ISO 3964.

Angular screwing instrument, available alternatively for hand drive or micro motor with INTRA coupling acc. to ISO 3964.

Destornillador de angulo, seleccionable a impulso de mano o micromotor con INTRA-acoplamiento según ISO 3964.

Tournevis angulaire, alternativement à commande manuelle ou avec micromoteur avec INTRA-accouplement selon ISO 3964.

Strumento per viti ad angolo, con scelta di uso a comando manuale oppure con il micromotore con INTRA-Aggiunto secondo ISO 3964.



Nou-Clean-Spray No. 1984

Nou-Clean Ölspray, 500 ml, zur Pflege der Handstücke

Nou-Clean oil spray, 500 ml, for the maintenance of hand pieces

Spray de aceite Nou-Clean, 500 ml, para el mantenimiento de las piezas de mano

Spray d'huile Nou-Clean, 500 ml, pour l'entretien des pièces à main

Olio spray Nou-Clean, 500 ml, per la manutenzione dei portastrumenti

No. 1709

Fett für 3-Weg-Hahn

Grease for 3-Way Valve

Grasa para 3-Vias Válvulas

Graisse pour 3-Voies Robinets

Grasso per 3-Vie Rubinetto

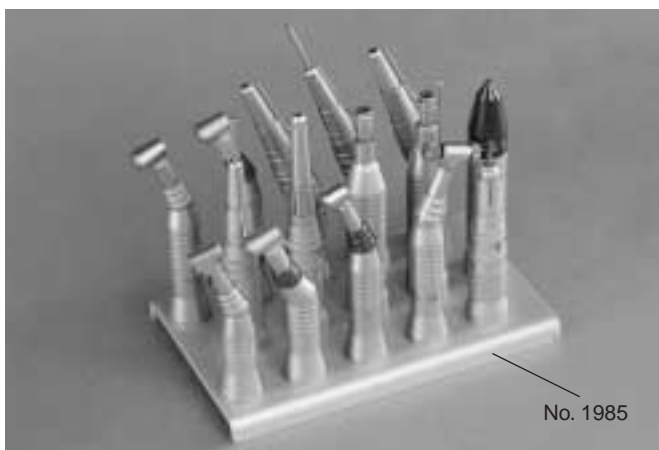

No. 1985

Ständer für 15 Hand- und Winkelstücke

Support for 15 hand pieces and contra angles

Soporte para 15 piezas de mano rectas y anguladas

Support pour 15 pièces à main et pièces angulaires

Supporto per 15 portastrumenti e angolari

**Bohrer
Burrs
Brocas
Fraises
Perforatori**

«Rosen»-Bohrer, **70 und 95 mm** lang, Schaft-Ø 2,35 mm
 «Rosen» Burrs, **70 and 95 mm** long, shank diameter 2.35 mm
 Brocas «Rosen», largo **70 y 95 mm**, Ø de vástago 2,35 mm
 Fraises de «Rosen», **70 et 95 mm** de long, Ø de tige 2,35 mm
 Perforatori «Rosen», **70 e 95 mm** lungo, asta Ø 2,35 mm

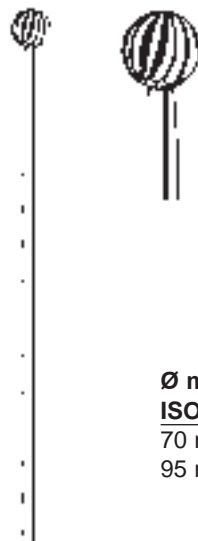

Ø mm	0,6	0,7	0,8	1	1,4	1,8	2,3
ISO-No.	006	007	008	010	014	018	023
70 mm	2750	2751	2752	2753	2754	2755	2756
95 mm					2774	2775	2776

Ø mm	2,7	3,1	3,5	4	4,5	5	6	7
ISO-No.	027	031	035	040	045	050	060	070
70 mm	2757	2758	2759	2760	2761	2762	2763	2764
95 mm	2777	2778	2779	2780	2781	2782		2784

mit extrem schlankem Schaft für die Mikro-Ohrchirurgie
 with extremely fine shaft for micro ear surgery
 con vástago extremadamente fino para la cirugía-micro oído
 à tige très élancée pour la chirurgie micro de l'oreille
 con asta molto fine per la chirurgia-micro orecchio

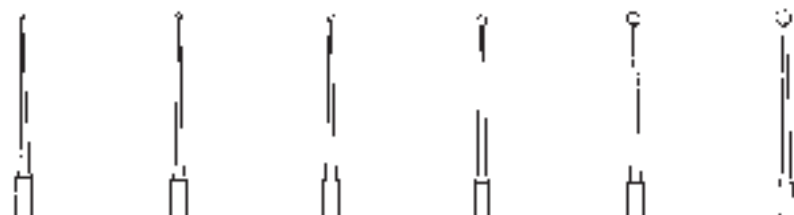

Ø mm	0,6	0,7	0,8	1	1,4	1,8
ISO-No.	006	007	008	010	014	018
70 mm	2765	2766	2767	2768	2769	2770

Fräser «Lindemann», Schaft-Ø 2,35 mm
 «Lindemann» Cutting Burrs, shank diameter 2.35 mm
 Fresas «Lindemann», Ø de vástago 2,35 mm
 Fraises de «Lindemann», Ø de tige 2,35 mm
 Frese «Lindemann», asta Ø 2,35 mm

nicht für 1960, 1961, 1962
 not suitable for 1960, 1961, 1962
 no para 1960, 1961, 1962
 ne s'applique pas pour les réf. 1960, 1961, 1962
 non per 1960, 1961, 1962

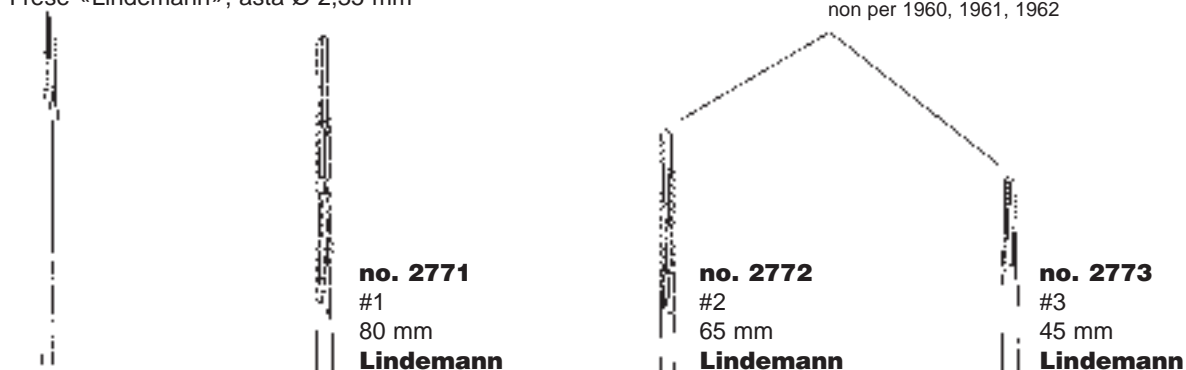

no. 2771 #1 80 mm Lindemann	no. 2772 #2 65 mm Lindemann	no. 2773 #3 45 mm Lindemann
--	--	--

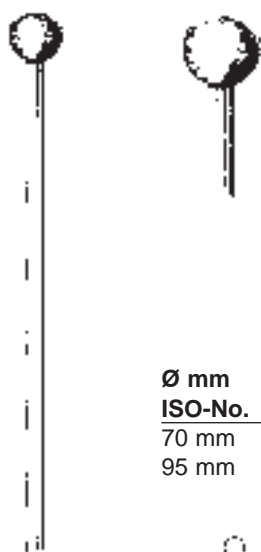

Diamantbohrer, **70 und 95 mm** lang, Schaft-Ø 2,35 mm
 Diamond Dust Polishing Burrs, **70 and 95 mm** long, shank diameter 2.35 mm
 Brocas diamantadas, largo **70 y 95 mm**, Ø de vástago 2,35 mm
 Fraises à polir, diamantées, **70 et 95 mm** de long, Ø de tige 2,35 mm
 Perforatori diamantati, **70 e 95 mm** lungo, asta Ø 2,35 mm



Ø mm	0,6	0,7	0,8	1	1,5	1,8	2,3
ISO-No.	006	007	008	010	015	018	023
70 mm	2850	2851	2852	2853	2854	2855	2856
95 mm					2874	2875	2876



Ø mm	2,7	3,0	3,5	4	4,5	5	6	7
ISO-No.	027	031	035	040	045	050	060	070
70 mm	2857	2858	2859	2860	2861	2862	2863	2864
95 mm	2877	2878	2879	2880	2881	2882		2884

mit extrem schlankem Schaft
für die Mikro-Ohrchirurgie
 with extremely fine shaft for
micro ear surgery
 con vástago extremadamente fino
para la cirugía-micro oído
 à tige très élancée pour la
chirurgie micro de l'oreille
 con asta molto fine per la
chirurgia-micro orecchio



Ø mm	0,6	0,7	0,8	1	1,5	1,8
ISO-No.	006	007	008	010	015	018
70 mm	2865	2866	2867	2868	2869	2870

Sägebohrer nach Hough für die Crurotomie, **65 mm** lang, Schaft-Ø 2,35 mm
 Hough Burr-Saws for Crurotomy, **65 mm** long, shank diameter 2.35 mm
 Brocas de sierra según Hough para la crurotomía, largo **65 mm**, Ø de vástago 2,35 mm
 Fraises, forme de scie, de Hough, pour la crurotomie, **65 mm** de long, Ø de tige 2,35 mm
 Perforatori a sega di Hough per crurotomia, **65 mm** lungo, asta Ø 2,35 mm



glatte Schneide
non-serrated cutting edge
corte liso
tranchant lisse
taglio liscio

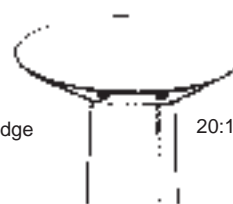

Ø mm	0,8	1	1,2	2,7	Ø mm	0,8	1	1,5
ISO-No.	008	010	012	027	ISO-No.	008	010	015
	2845	2846	2847	2848		2871	2872	2873

Bohrer
Burrs
Brocas
Fraises
Perforatori



Bohrer mit Dentalschaft, Hartmetall, **22 mm** lang, Schaft-Ø 2,35 mm
 Cutting Burrs with dental shank, tungsten carbide, **22 mm** long, shank diameter 2.35 mm
 Brocas con vástago dental, tungsteno, largo **22 mm**, Ø de vástago 2,35 mm
 Fraises à tige dentaire, carbure, **22 mm** de long, Ø de tige 2,35 mm
 Perforatori con asta dentale, tungsteno, **22 mm** lungo, asta Ø 2,35 mm



Ø mm	0,6	0,7	0,8	0,9	1
ISO-No.	006	007	008	009	010
	2810	2811	2812	2813	2814

Verpackungseinheit 10 Stück
 Packaging unit 10 pieces
 En paquete de 10 piezas
 Unité d'emballage 10 pièces
 Confezione da 10 pezzi



Ø mm	1,2	1,4	1,6	1,8	2,1	2,3
ISO-No.	012	014	016	018	021	023
	2815	2816	2817	2818	2819	2820

passend für Handstücke • fitting hand pieces • adaptable a piezas de mano • s'adaptant aux pièces à main • adattabili al manipolo



Ø mm	0,5	0,7	1	1,5	1,8	2,0	2,5	3,0	3,5
ISO-No.	005	007	010	015	018	020	025	030	035
	2830	2831	2832	2833	2834	2835	2836	2837	2838



Ø mm	4	4,5	5	6	7
ISO-No.	040	045	050	060	070
	2839	2840	2841	2842	2843

passend für Handstücke • fitting hand pieces • adaptable a piezas de mano • s'adaptant aux pièces à main • adattabili al manipolo



HSS Spiralbohrer, 44 mm lang, Schaft-Ø 2,35 mm
HSS Twist Drills, 44 mm long, shank diameter 2.35 mm
HSS Brocas espirales, largo 44 mm, Ø de vástago 2,35 mm
HSS Fraises en spirale, 44 mm de long, Ø de tige 2,35 mm
HSS Perforatori elicoidali, 44 mm lungo, asta Ø 2,35 mm

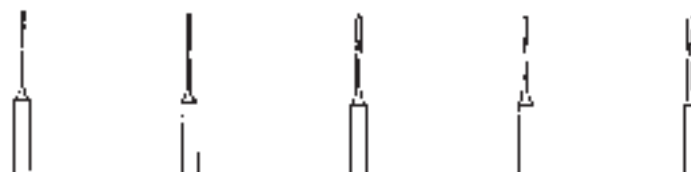

Ø mm	0,5	0,6	0,7	0,8	0,9
ISO-No.	005	006	007	008	009
	2785	2786	2787	2788	2789



Ø mm	1	1,1	1,2	1,3	1,4
ISO-No.	010	011	012	013	014
	2790	2791	2792	2793	2794

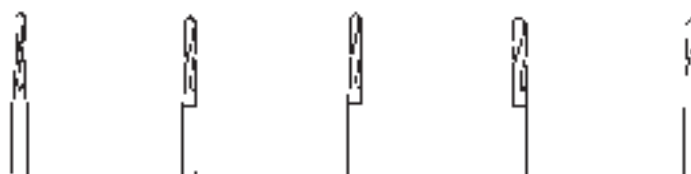

Ø mm	1,5	1,6	1,8	2,1	2,3
ISO-No.	015	016	018	021	023
	2795	2796	2797	2798	2799

Perforationsbohrer für die Fussplatte, **65 mm** lang, Schaft-Ø 2,35 mm, Trokarspitze
Perforating Burrs for footplate, **65 mm** long, shank diameter 2.35 mm, trocar point
Brocas de perforación para placa de pie, largo **65 mm**, Ø de vástago 2,35 mm, punta de trocar
Fraises (perforateurs) pour la platine stapédienne, **65 mm** de long, Ø de tige 2,35 mm, pointe en trocart
Perforatori per stapectomia del piede, **65 mm** lungo, asta Ø 2,35 mm, punta a trocar

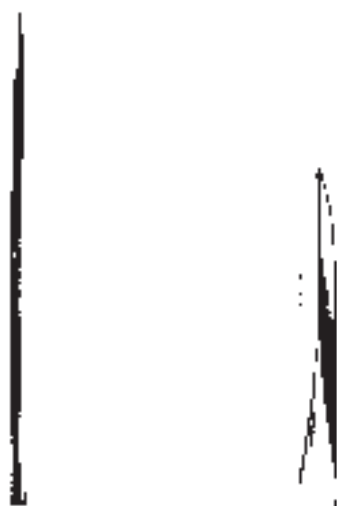

Ø mm	0,8	1	1,15
ISO-No.	008	010	0115
	2801	2802	2803

Finierer
Polishing Burrs
Fresa terminal
Fraises à finir
Frese per ultima finitura

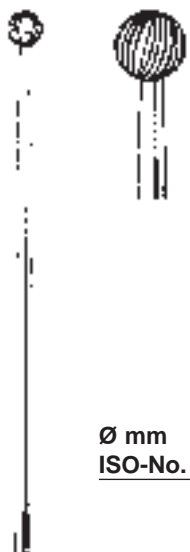

Finierer, **70 mm** lang, Shaft-Ø 2,35 mm
 Polishing Burrs, **70 mm** long, shank diameter 2.35 mm
 Fresas terminales, largo **70 mm**, Ø de vástago 2,35 mm
 Fraises à finir, **70 mm** de long, Ø de tige 2,35 mm
 Frese per ultima finitura, **70 mm** lungo, asta Ø 2,35 mm

Ø mm	0,7	0,8	1	1,4	1,8	2,3	2,7
ISO-No.	007	008	010	014	018	023	027
	2701	2702	2703	2704	2705	2706	2707
Ø mm	3,1	3,5	4	4,5	5	6	7
ISO-No.	031	035	040	045	050	060	070
	2708	2709	2711	2712	2713	2714	2715



Fräser, Form «Knospe», **95 mm** lang, Schaft-Ø 2,35 mm
 Cutting Burrs, style «bud», **95 mm** long, shank diameter 2.35 mm
 Fresas, en forma de capullo, largo **95 mm**, Ø de vástago 2,35 mm
 Fraises, en forme de bourgeon, **95 mm** de long, Ø de tige 2,35 mm
 Frese, forma di bocciolo, **95 mm** lungo, asta Ø 2,35 mm

Ø mm	5	7
ISO-No.	050	070
	2720	2721

THP 3000

Tätowierhandstück
Tattooing hand piece
Pieza de tatuaje
Pièce à main pour tatouage
Manipolo per tatuare

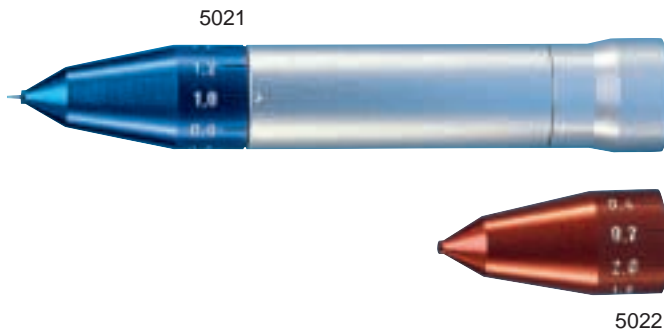

No. 5021

Nadeln 6/9/12
 Needles 6/9/12
 Agujas 6/9/12
 Aiguilles 6/9/12
 Aghi 6/9/12

No. 5022

Nadeln 1/3
 Needles 1/3
 Agujas 1/3
 Aiguilles 1/3
 Aghi 1/3

No. 5020

Tätowierhandstück komplett mit INTRA-Kupplung nach ISO 3964, verstellbare Einstichtiefe; ohne Tätowiernadeln; hygienisch: zur Pflege und Reinigung zerlegbar.

Tattooing Hand piece complete with INTRA Coupling acc. to ISO 3964, without tattooing needles; hygienic: easily dismountable for maintenance and cleaning.

Pieza de tatuaje completa con Acoplamiento INTRA según ISO 3964, profundidad de la punción ajustable; sin agujas de tatuaje; higiénico: desmontable para mantenimiento y limpieza.

Pièce à main pour tatouage, complète, avec INTRA-Accouplement selon ISO 3964, profondeur de la ponction réglable, sans aiguilles pour tatouage; hygienique: peut être démontée pour l'entretien et le nettoyage.

Manipolo per tatuare, completo con INTRA-Aggiunto sec. ISO 3964 profondità della punta regolabile; senza ago per tatuare; igiene: smontabile per pulitura e lavaggio.

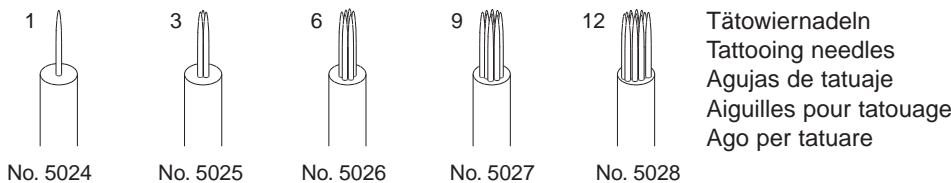

Tätowiernadeln
 Tattooing needles
 Agujas de tatuaje
 Aiguilles pour tatouage
 Ago per tatuare



Pigmentier-Farben, steril

Alle Permanentfarben sind aus antiallergenen Mineralstoffen hergestellt, garantiert verträglich, farbecht und optimal mischbar, geeignet für jeden Hauttyp.

Colour Pigments, sterile

All the colour pigments are of a hypoallergenic mineral origin, are colourfast – can be easily mixed and are suitable for all types of skin.

Colores de pigmento, estériles

Todos los colores son permanentes y duraderos de origen mineral, garantizadamente compatibles y simple de mezclar, adecuado para todos los tipos de piel.

Couleurs pigment, stériles

Toutes les couleurs pigment sont d'origine minérale antiallergique, assurément supportables et de grand teint, optimal pour mélanger et appropriées pour tous les types de peau.

No. 9570–9598

Pigment-Farben, 10 ml, steril
 Colour Pigments, 10 ml, sterile
 Couleurs Pigments, 10 ml, stérile

Colori per la pigmentazione, sterili

Questi colori sono a base minerali, compatibilità garantita, facile a mescolare, adatto per tutti i tipi di pelle.

